

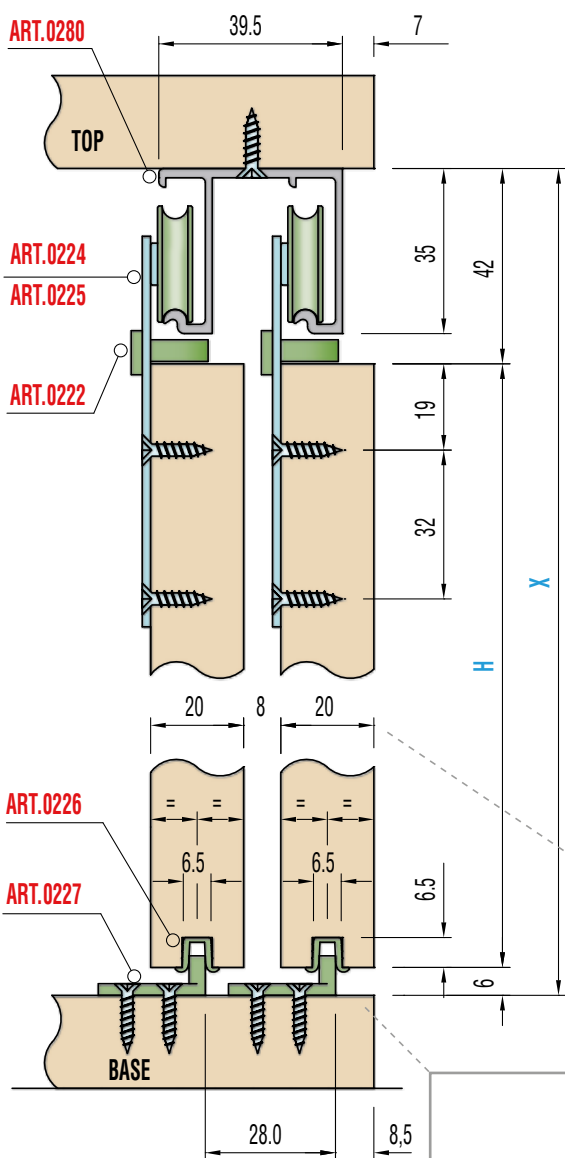

Sistemi scorrevoli per mobili / Sliding systems for furniture

**Sezione verticale / Vertical section**

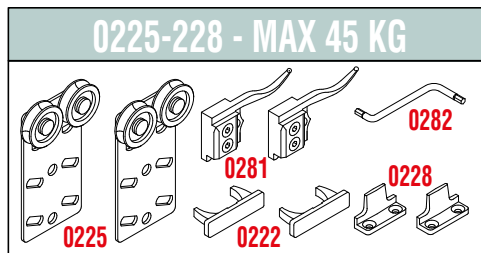
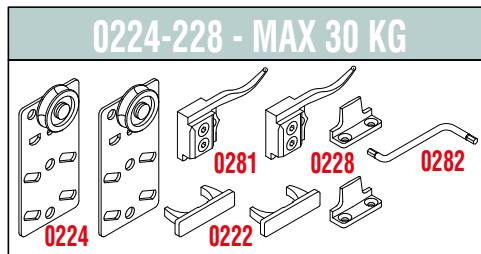
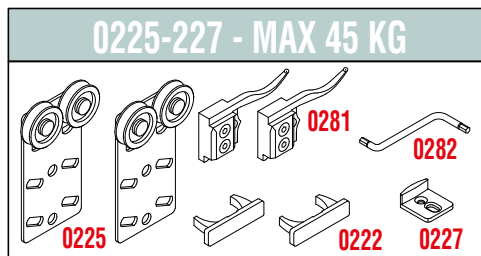
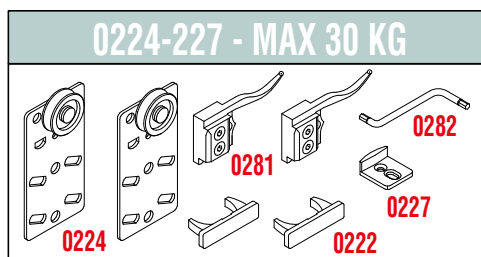

Peso massimo anta Kg. 30  
con Art. 224  
Maximum door weight  
Kg 30 with Art. 224

Peso massimo anta Kg. 45  
con Art. 225  
Maximum door weight  
Kg 45 with Art. 225

H = X - 48

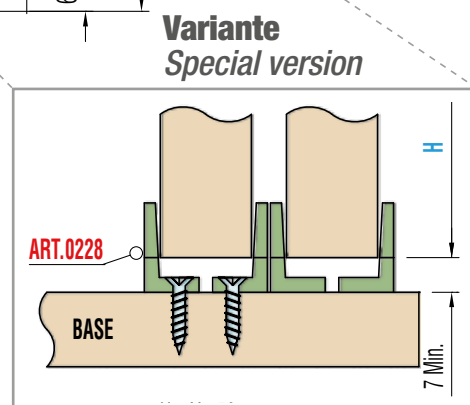

H = X - 49

**Legenda KIT / Kit Legend**

<b>0281</b>	Fermo superiore Upper stopper
<b>0222</b>	Antisganciamento per art.0224 e 0225 Clasp for art.0224 e 0225
<b>0224</b>	Carrello superiore con 1 cuscinetto Upper Truck with 1 ball bearing
<b>0225</b>	Carrello superiore con 2 cuscinetti Upper Truck with 2 ball bearings
<b>0227</b>	Guida inferiore Lower guide
<b>0228</b>	Guida inferiore Lower guide
<b>0282</b>	Chiave esagonale 3 mm piegata Hexagonal key 3 mm

**Legenda altri componenti  
Legend other items**

<b>0280</b>		Profilo alluminio superiore Upper aluminium profile
<b>0226</b>		Profilo plastica inferiore Lower plastic profile

**Schema Foratura ante / Doors drilling**

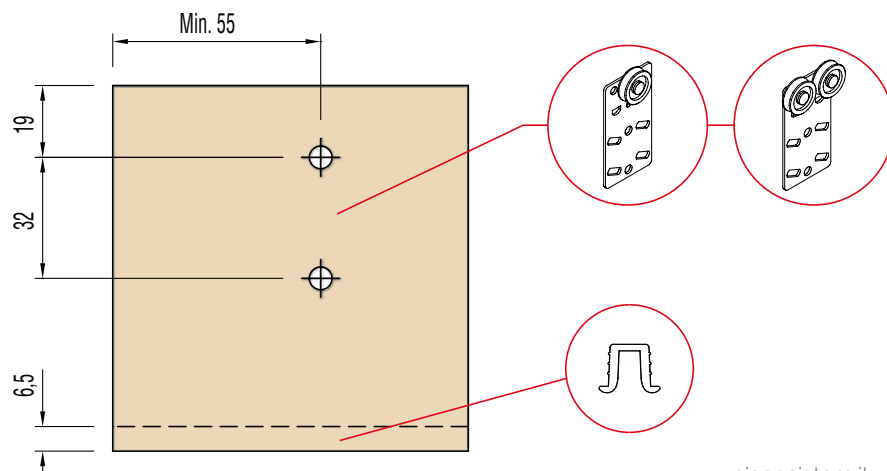



## Sezione verticale / Vertical section

### Anta esterna / Outer door

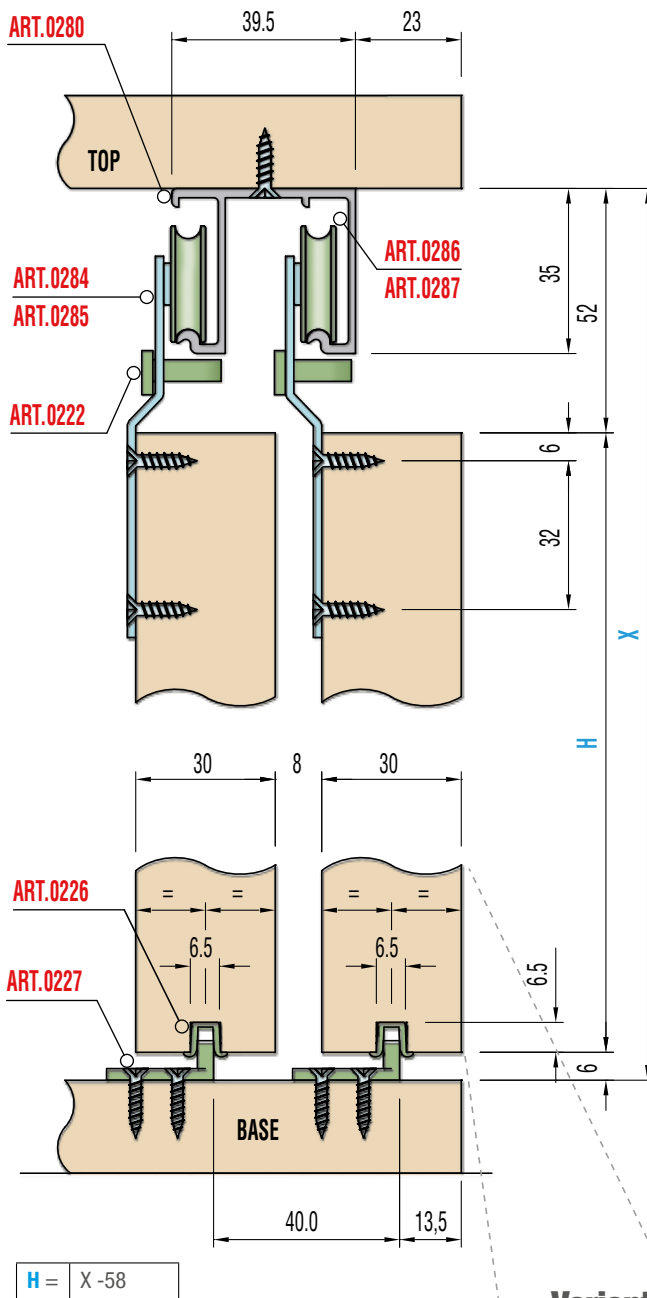
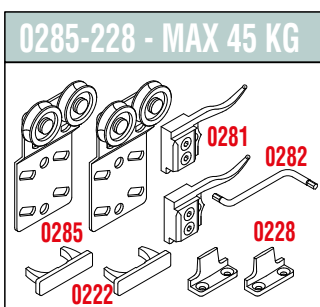
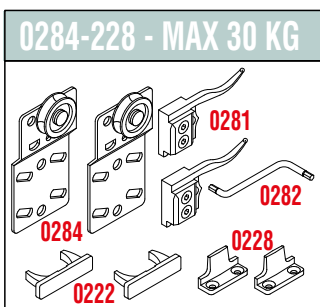
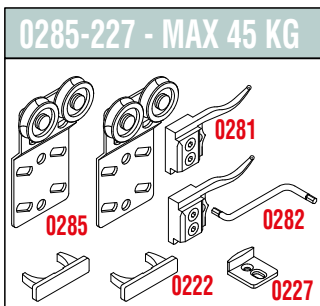
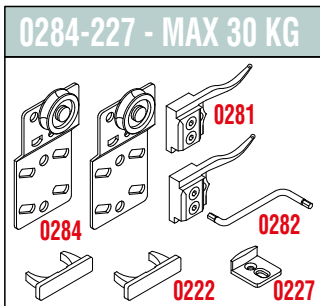

### Anta interna / Inner door

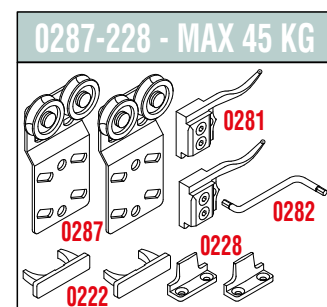
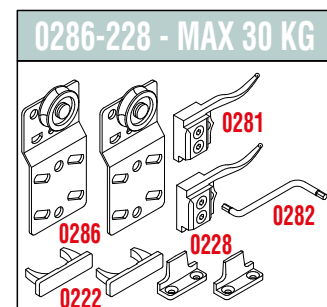
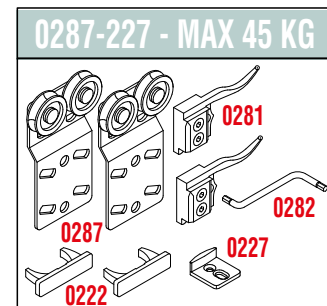
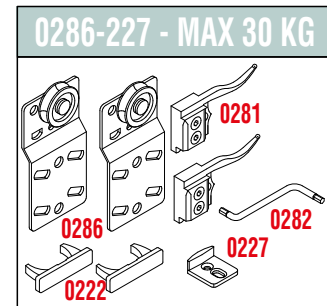

### Variante Special version

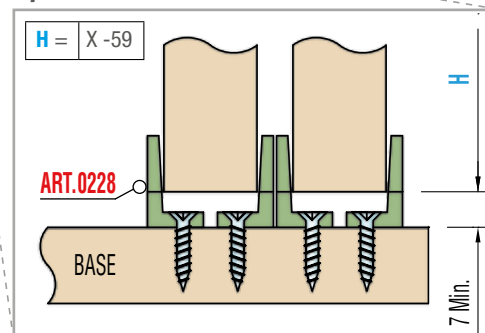

### Legenda altri componenti Legend other items

<b>0280</b>		Profilo alluminio superiore Upper aluminium profile
<b>0226</b>		Profilo plastica inferiore Lower plastic profile

### Legenda KIT / Kit Legend

<b>0281</b>	Fermo superiore Upper stopper
<b>0222</b>	Antisganciamento per art.0224 e 0225 Clasp for art.0224 e 0225
<b>0284</b>	Carrello con 1 cuscinetto con piega Truck with 1 ball bearing with groove
<b>0285</b>	Carrello con 2 cuscinetti con piega Truck with 2 ball bearings with groove
<b>0286</b>	Carrello con 1 cuscinetto con piega Truck with 1 ball bearing with groove
<b>0287</b>	Carrello con 2 cuscinetti con piega Truck with 2 ball bearings with groove
<b>0227</b>	Guida inferiore Lower guide
<b>0228</b>	Guida inferiore Lower guide
<b>0282</b>	Chiave esagonale 3 mm piegata Hexagonal key 3 mm

### Schema Foratura ante Doors drilling

